

# Easy High Dynamic Range Imaging for Welding Vision

V.Noguier, F. Volonteri, S. Ambert, J.L. Lauront, Y.Ni,

New Imaging Technologies. 1 Impasse de la Noisette. 91370 Verrieres Le Buisson. France

## ABSTRACT

Welding has long been a key technology for assembling metals parts in various industries. Nowadays with the constant search of quality and productivity, welding has become increasingly sophisticated with the introduction of new processes and the automation of these processes. It is essential to visualize and monitor, in great details and as closest as possible, the weld pool (melt metal) during and/or after the process for ensuring quality, consistency, and reproducibility of assembly. This is a particularly difficult task when considering the high temperature, high level and fast variation of light intensity, and high contrast generated during these operations.

**Keywords :** GTAW/TIG, GMAW/MIG, MAG, LBW, YAG, Laser Cladding, Hybrid Welding, Induction Welding, High Dynamic Range, LAM, SWIR, Thermography

## 1. Introduction

Based upon the principle of reaching metal fusion by applying a heat source in order to connect metal parts together, the welding technologies remain one of the most widespread techniques for assembly in many industrial production areas. Plasma and arc processes have been further completed by laser (**YAG**), electron beam or induction technologies. They all share in common several key parameters that may considerably vary including high temperature, high light intensity, process stability or speed which render the use of camera control more complex. Indeed, the level of contrast between a plasma, an arc or a laser and the so called “weld pool” + the two side metal parts of joint is extremely high and more or less stable depending on process. Additional challenge is the specular reflections that may occur on shiny material such as aluminum or by the shape of metal (lateral wall).

For a long time, high quality driven domains such as aeronautics, nuclear and medical have required track records of welding operation but now a massive trend for automation fosters the use of more artificial vision for all welding segments due to the need to improve general working conditions and health consideration.

To obtain an image, the industry has traditionally been using conventional CCD cameras or more recently CMOS imaging sensors with limited dynamic with additional filters (spatially variable neutral density filter, commutation filter using liquid crystal), thus resulting in material and software complexity, high cost and difficulties to implement on large scale. The long set-up optimization time, the delay between parameter adjustment and observed phenomenon and the fact that important details are still lacking are the main reasons that are pushing to search for new innovative vision technologies.

The Native WDR sensors based on our innovative patented logarithmic pixel design can be considered as the most adequate technology for this application. In recent years, we (NIT) have offered to OEM several Native WDR image sensors both in the visible (CMOS) and NIR/SWIR (InGaAs). These sensors allow our OEM customers to design and produce analogue or digital cameras with incomparable image quality and also an ease of use without any adjustment. Existing tracking algorithms were used by customers without any adaptation to our sensors. The Native WDR technology has been implemented in different products. With rolling shutter or snapshot readouts, monochrome or color micro filters and even TEC temperature stabilized solutions capable of calibrated radiometric metrology (thermography), a whole range of products are available to meet customer requirements. This white paper can help our customers to understand the technical distinction of our products and make the most adequate choice.

## 2. Welding vision challenge

The main challenge in this field is high dynamic range and can be summarized by the following characteristics:

1. Extremely high intra-scene contrast range
2. Extremely fast and large variation of light intensity between successive frames (inter-scene contrast range)
3. Harsh environment with high temperature, smoke, sparks, dust...

The first 2 points should be addressed by image sensors. Our Native WDR pixel with its logarithmic response can cover more than 140dB in a single exposure during the image sensing stage. Thanks to this outstanding dynamic range, it can cover easily both intra and inter scene contrast in the image without loss of information. Additional post sensing image processing can further improve the image quality to adapt to human observation and/or machine vision.

The 3<sup>rd</sup> point will be naturally addressed by our customers with their experiences in this field. Basically each process represents its own challenge when it comes to **real time visualization** of what is actually happening at the welding end with a maximum of content information. Once again, NIT technology is interesting as the behavior of the log response is suitable to high ambient temperatures.

One can distinguish two process families whether they are continuous or pulsed.

### a. GTAW/TIG

**Gas Tungsten Arc Welding (GTAW)**, also known as **Tungsten Inert Gas (TIG)** welding, is an arc welding process that uses a non-consumable Tungsten electrode for producing the heat for welding that is normally protected from atmospheric contamination by an inert shielding gas (Argon, Helium). **A constant current** welding power supply produces electrical energy, which is conducted across the arc through a column of highly ionized gas and metal vapors known as plasma (Fig.1). This process can be automated unlike Manual Metal Arc Welding. The parameters to be monitored visually are the standoff, the offset and the contact point (Fig.2)

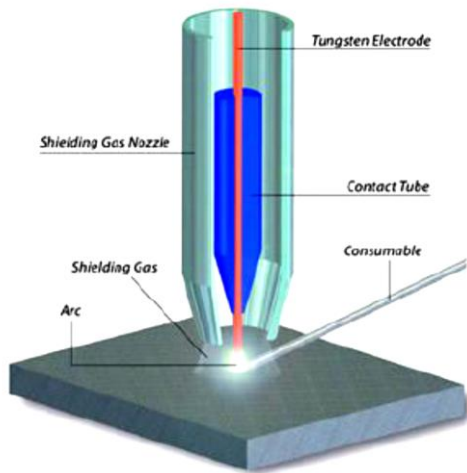

**Fig.1 GTAW**

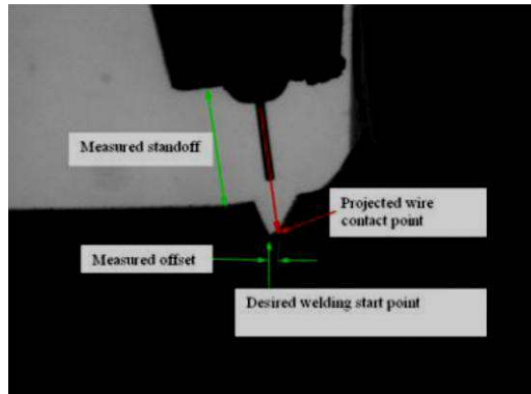

**Fig.2 Welding parameters**

**b. GMAW/MIG –MAG**

**Gas Metal Arc Welding (GMAW)**, also known as **Metal Inert Gas (MIG)** welding or Metal Active Gas (MAG) welding, is a process where an electric arc forms between a consumable wire electrode feed axially in welding gun and the metals work-piece (Fig. 3). Heat generated by the arc causes metals work-pieces to melt and join. Like for described previous process, a shielding gas feeding through the welding gun is used for protecting weld from atmospheric contamination. This process can be semi or fully automated and most commonly uses a **constant voltage, direct current** power source; the latter can be either **constant or alternating (Pulsed)**. Four different metal transfer methods - which will not be detailed here - can be used; globular, short-circuiting, spray and pulsed-spray.

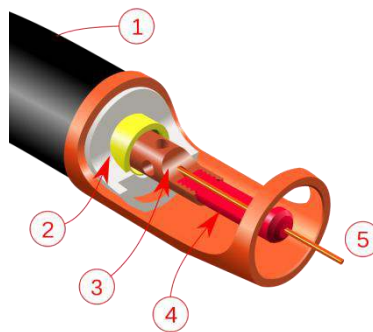

**Fig. 3 GMAW torch**

(1) Torch handle, (2) Molded dielectric (white) & threaded metal nut insert (yellow), (3) Shielding gas diffuser, (4) Contact tip, (5) Nozzle output face

Again, the parameters to be monitored visually are the spatial location of different elements and the nature and configuration of the weld pool (lateral edge, bubble formation...).

**c. Laser**

**Laser Beam Welding (LBW)** is a welding technique used to join multiple pieces of metal through the use of a laser. Characterized by its high power density, it results in small heated zones and high heating and cooling rates. The beam provides a concentrated heat source, allowing narrow, deep welds and high welding rates (Fig.4). The process is frequently used in high volume

applications such as in the automotive industry or for medical devices thanks to the lack of distortion. The process monitoring often extends to the cooling phase where temperature measure (absolute or relative) is mandatory.

The use of laser has considerably increased in the recent years thanks to fiber-laser and now extends to other areas such as **Laser Cladding** and **Laser Additive Manufacturing LAM** (Fig.5), **Hybrid Welding** (combining arc and laser welding)...

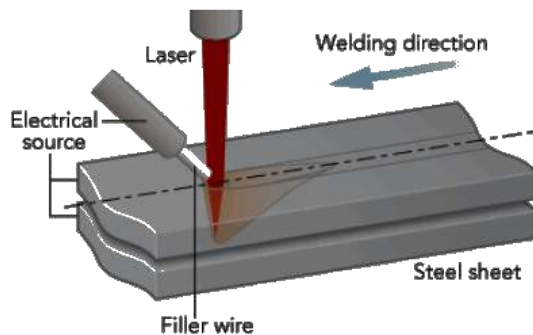

**Fig .4 LBM principle**

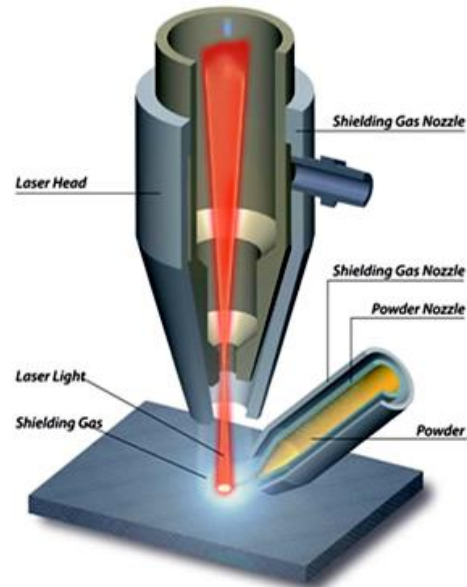

**Fig.5 LAM principle**

The mains laser used are YAG laser (1064 nm) and CO2 laser (10.6  $\mu\text{m}$ )

#### d. Others

**Electron Beam Welding (EBW)** is a fusion welding process where high-velocity electrons beam is applied to two materials to be joined. Carried out under vacuum conditions to prevent dissipation of electron beam, the work pieces melt and flow together under action of kinetic energy converted in heat upon impact.

**Induction Welding** uses electromagnetic induction to heat the work-pieces. An induction coil is powered with radio frequency electric current generating high frequency electromagnetic field in either electrically conductive work-pieces ( heating by Joule effect via Eddy currents), ferromagnetic work-pieces (heating by hysteresis of magnetic material distortion domain). In practice, most materials undergo a combination of these two effects.

### 3. NIT's Native WDR Solution

#### a. Technology basics

New Imaging Technologies Image sensors are based upon our patented Native WDR technology where each pixel produces a logarithmic response in function of light intensity. Compared to traditional logarithmic pixel design, our Native WDR technology removes the image lags and also reduces considerably the FPN to an almost eye non-noticeable level. It uses photodiode in solar cell mode where the photovoltaic voltage on the open-circuit photodiode is read as image signal which is proportional to the logarithm of incident light intensity (see Fig.6 ). It behaves like if the

sensor has an infinite full well capacity. So >140dB high contrast scene, both intrascene and interscene, can be sensed directly by Native WDR pixel in one exposure and without any image processing.

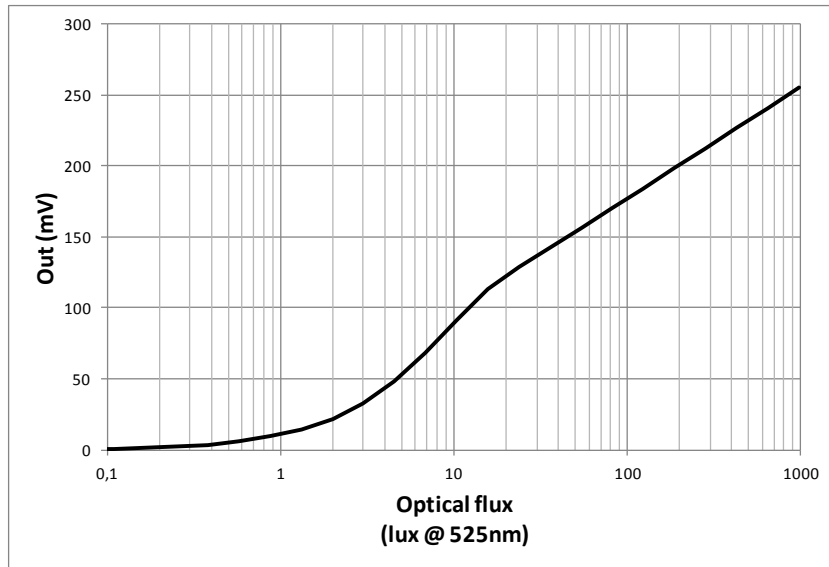

**Fig. 6 NSC0902 sensor response**

**b. Products in visible-NIR spectrum**

**i. Rolling shutter sensors**

Rolling shutter sensors have a simple pixel design and offer a stable image with lower noise than global shutter counterparts. For the welding processes using constant current, rolling shutter image sensors are good choices for welding cameras.

The NSC0902 sensor (768 x576 pixels -5.6 $\mu$ m pitch) is ideal for welding processes such as GTAW. The pixels are constantly exposed and the reading mode is done row by row. The internal differential readout removes FPN and gives clean image directly. Besides it can output directly CCTV signal by using the on-chip encoding circuit, ideal for small size, low power and low cost welding cameras compatible with CCIR or EIA display. The circuit block diagram of sensor is shown in Fig.7

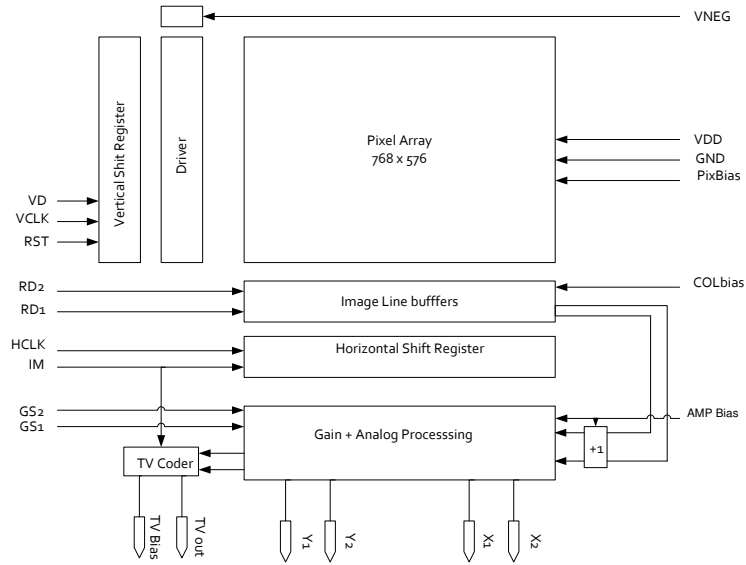

**Fig.7 Function block diagram of NSC0902.**

Images - captured on movies - beneath illustrates results that can be reached: Fig.8 comparative between NSC0902 on left and CCD on right. GTAW Fig.9



*Courtesy of Labotron*

**Fig.8 Comparative NSC0902/CCD**

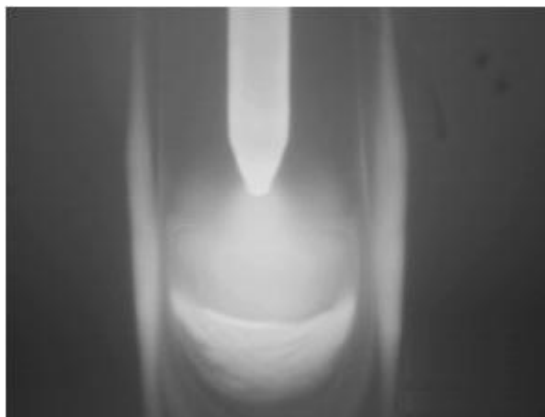

*Courtesy of Areva&M8*

**Fig.9 GTAW illustration**

## ii. Global shutter sensors

When using pulsed current or constant voltage power supply, the current of the welding arc can suddenly change either due to pulsing or due to arc formation and extinction. The generated light intensity variation is huge and fast. NIT's rolling sensors can accommodate the dynamic range without any problem but the progressive reading on the pixels in the pixel array generates unacceptable artifacts. Global shutter sensors, where the photodiodes in all the pixels are sensed at the same time and the readout signals are stored on in-pixel memories can remedy to this.

The NSC1003 sensor (1280 x1024 pixels, 6.8µm pitch) has global shutter capability and is ideal for the welding processes where light intensity is unstable such as GMAW, LBW. It is available in both monochrome and color version, and gives the opportunity to design and manufacture HD-ready digital welding camera.

The circuit block diagram of NSC1003 sensor is shown in Fig.10

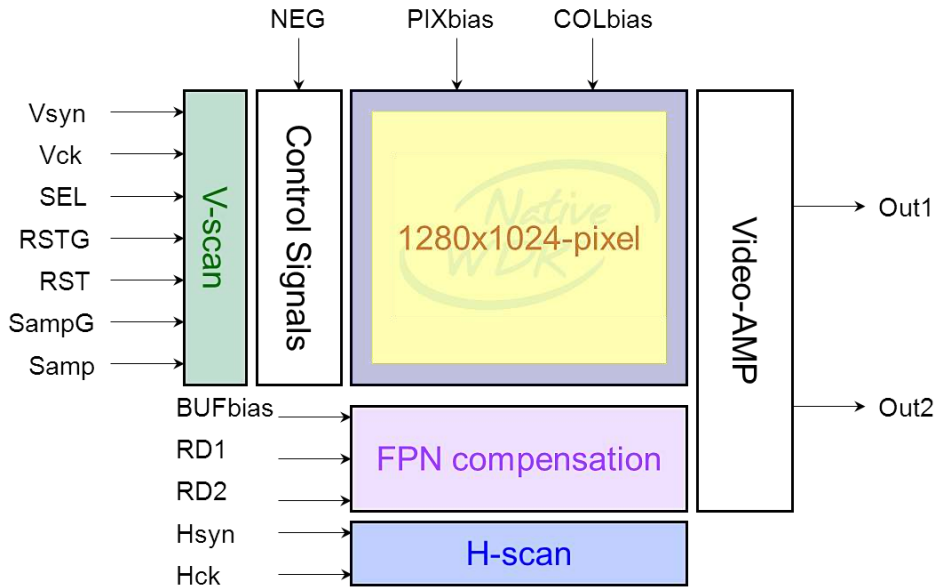

**Fig.10 Function block diagram of NSC1003**

It should be noted that NIT logarithmic sensor doesn't integrate light, so only the instant light intensity at the sampling period is taken into video signal. Fig. 11 shows the difference of behavior between a NSC1003 and a classic CCD, both set at 100µs exposure time. The CCD will integrate during all exposure time while NIT NSC1003 will capture only the last part of the exposure time. This can generate some image difference when very short light pulses are present on the scene.

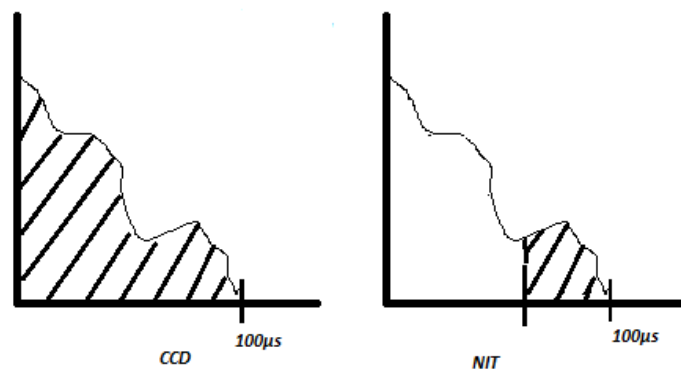

**Fig.11 Comparative behavior between CCD/NSC1003 for 100µs exposure**

The three following images –captured in movies - give examples of image taken by cameras using NSC1003: respectively TIG on Aluminum (Fig.12), Mirror-Weld project (Fig.13), Laser Cladding (Fig.14 ).



*Courtesy of Xiris automation*

**Fig.12 TIG on Aluminum**



View from Visible Welding video goggles



Normal video cameras can't show the blinding welding arc

*Courtesy Visible Welding*

**Fig.13 Mirror-Weld project**

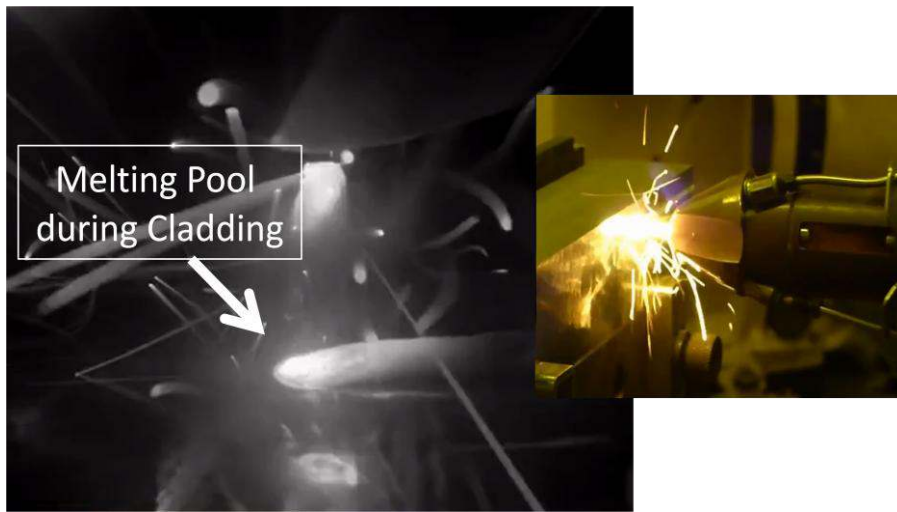
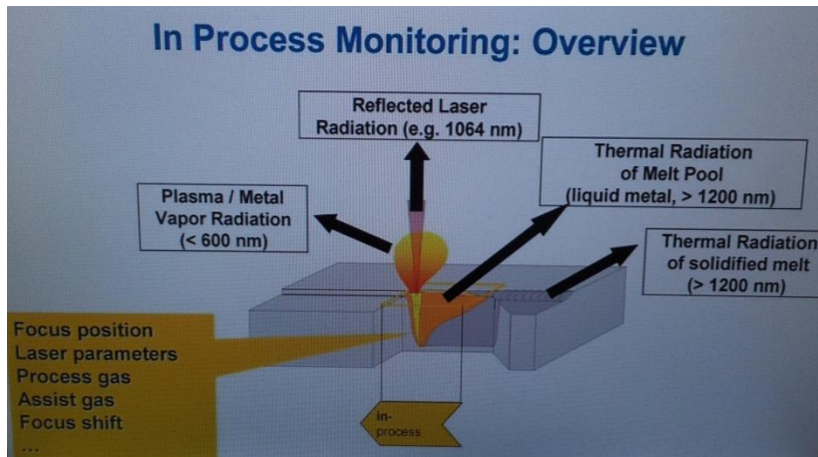

**Fig. 14 Laser cladding imaging with NSC1003** *Courtesy of Institut Maupertuis*

**c. Products in SWIR spectrum**

NIT provides a series of Native WDR sensors by using InGaAs photodiode array hybridized to CMOS readout circuit. Such Short Wave InfraRed (SWIR) cameras work both in reflective imaging mode (like visible) and direct irradiation detection mode (corresponding to hot objects with  $>250^{\circ}\text{C}$  temperature). With a spectral response from 900-1700 nm, they are particularly well adapted for welding vision. Both weld pool and solidified melt are clearly seen while plasma and metal vapor are not visible as depicted in Fig. 15. In addition, as SWIR sensors have an improved ability to see through smoke, they can allow users to image in real time numerous details of the weld bead, for assessing its size, appearance & shape and even for controlling its heat profile.





Courtesy of Precitech

**Fig. 15 Wavelength emission of different element during LBW**

NIT offers InGaAs sensor in both QVGA (320 x256 pixels, 25µm pitch – rolling NSC0803-SI or global/snapshot NSC1401-SI) and VGA (640x512 pixels, 15µm pitch – global/snapshot NSC1201-SI) with Native WDR capability, like NIT visible CMOS sensors, bearing a high dynamic range of >140db. When calibrated, they can also provide a radiometric measurement such as used in thermography camera; camera facing blackbody, response curve versus temperature (Fig.16 & 17)

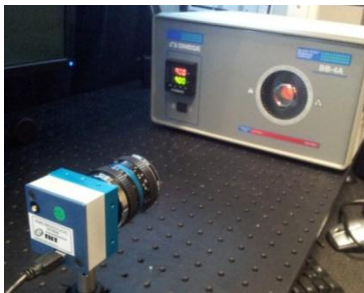

**Fig.16 Widy SWIR 320U facing black body**

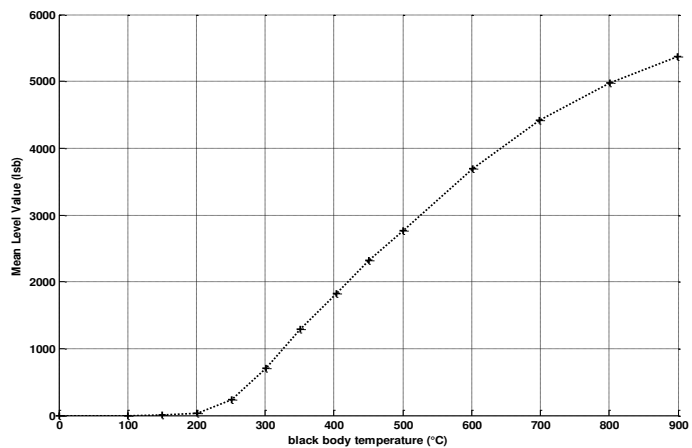
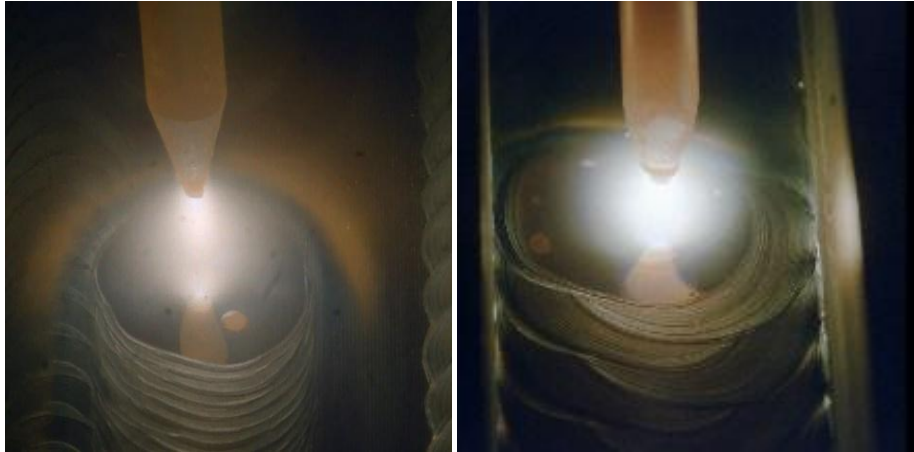

**Fig.17 Widy SWIR response (DL count vs T°C)**

**d. Optimization of scene capturing**

**i. Optical filters**

Knowing that the spectral light emitted by the process is extremely different from process to process, the use of special band-pass optical filters can greatly improve the image quality or reveal the details in it. Fig.18 shows the effect of the application of a special filter (right image). It can be seen clearly that this filter improves the quality of the initial image (left image) and reveals more details.



*Courtesy of Polysoude*

**Fig.18 Images without (left) and with Filter**

### **ii. Background illumination**

Welding very often occur in dim shadowed areas. When the arc is not triggered, the scene can be too dim to produce good quality image. This is particularly the case during welding setup phase. An additional lighting can be used to overcome this problem. Today's high performance LEDs is the best solution to this problem. They are small and highly efficient to be integrated directly into a welding camera body.

### **iii. Post image processing**

Despite the fact that NIT's Native WDR can conserve all the visual details in a welding scene, the image display remains very often a problem since no image display device can have such high dynamic range. Some post image processing techniques can be used to improve image rendering on the display devices. NIT's cameras come with 14 bits (RAW) digitalized data, containing much more information than that a classic display with 8bits resolution can actually display. RAW datas can be used with profit for displaying useful information thanks to specific algorithm. An example is given in image beneath with machine vision tracking algorithms (Fig.19)

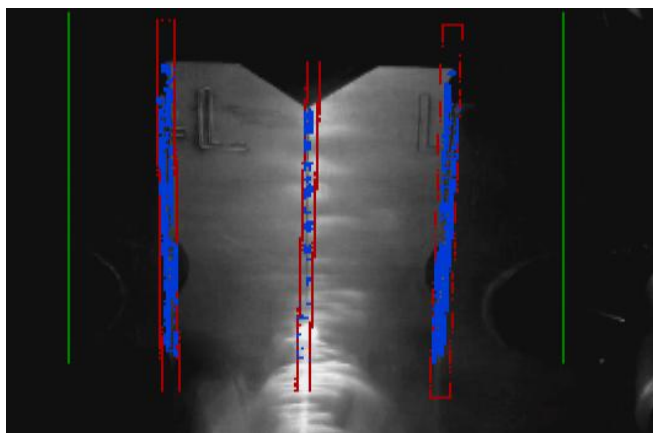

*Courtesy of Edixia Automation*

**Fig.19 Weld view with post processing algorithm**

Simple image post-processing such as gamma and false color (translating grey scale into color) can considerably improve the contextual understanding of image. An example of this with Widy SWIR 320U is shown in Fig.20

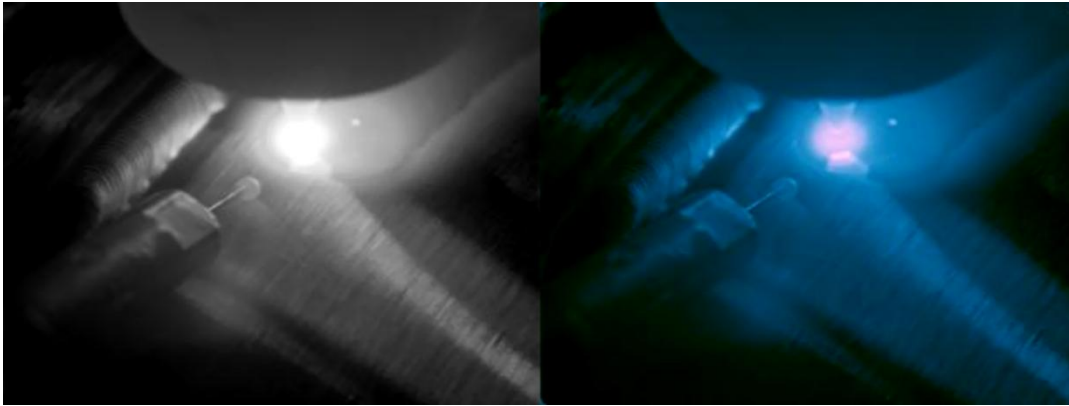

**Fig.20 8bits image on left, same image with gamma and false color on right**

New imaging technologies, as well as some of its customers, have developed several algorithms for auto gain control and local contrast image enhancement including Contrast Local Adaptive Histogram Equalization (CLAHE) where excess signal is distributed across the histogram (Fig. 21); Enhancement using bilateral filter (BILATERAL) filtering were performed separately on the image: a low-pass and a high-pass illustration of this latest algorithm is illustrated on (Fig.22)where original image is on the left, CLAHE in the middle and BILATERAL on the right.

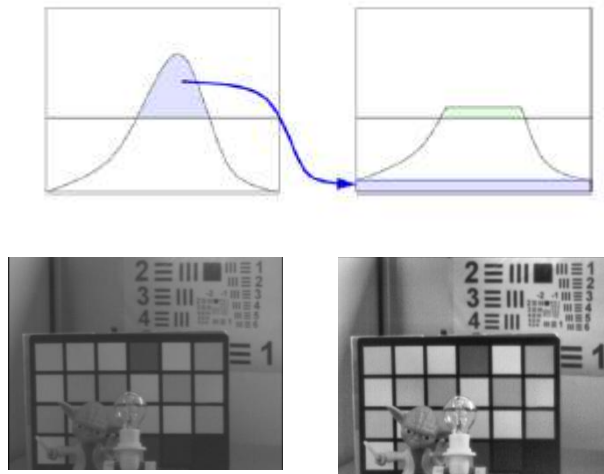

**Fig.21 CLAHE**



**Fig. 22 SWIR images; non processed on left, CLAHE in the middle, BILATERAL on right**

#### **4. Conclusion**

New Imaging Technologies is a French pure-play pioneer in new generation solar cell mode photodiode based logarithmic image sensors, sourcing from more than 15 years of academic research inside French Telecom University. Our expertise covers CMOS process, design and manufacturing as well as InGaAs process, design and manufacturing.

With sales partners in over 20 countries and more than 35 OEM design-in, we address most efficiently all customer requests around the globe or can redirect to our customer needs that could arise anywhere in the welding areas.

NIT offers a complete portfolio of cameras and detectors embracing Visible, Intensified (I-CMOS) and SWIR technologies. NIT serves various markets such as machine vision, instrumentation, night vision, biometrics...

NIT also proposes flexible solutions and custom designs to best fit your specific requirements

#### *References:*

1. *MAGIC technology white Paper.pdf*
2. *LOG image sensor with OnChip FPN compensation.pdf*
3. *Apn-welding applications.pdf*